

Structural health monitoring of a post-tensioned concrete bridge using wireless sensor network: deployment and evaluation

Niusha NAVABIAN¹, Sherif BESKHYROUN¹

¹ Auckland University of Technology, Auckland, New Zealand

Contact E-mail: niusha.navabian@aut.ac.nz

ABSTRACT: In this paper, a new developed wireless sensor unit is introduced and utilised to extract dynamic characteristics of a post-tensioned concrete bridge in New Zealand. The system includes 20 wireless sensor nodes and one base station unit. The sensor nodes use wireless mesh network to transfer the measurements including temperature, humidity and 3-axis acceleration. The advantages of the sensor nodes are its high resolution and sensitivity, low cost and power consumption to record both ambient and earthquake-induced vibrations using two time-triggered and event-triggered modes. To assess the condition of the superstructure over time, the bridge dynamic characteristics obtained using the vibration recorded from the structure are compared with the counterparts measured several years ago using standalone MEMS accelerometers. The dynamic characteristics of the bridge show a constant performance of the full-scale structure over its lifetime. Also, the results indicate a reliable performance of the developed wireless sensor system for monitoring of large-scale structures.

1 INTRODUCTION

Several important civil structures such as bridges, high-rise buildings, offshore platforms, and tunnels are being utilised despite their age and the possible risk of damage accumulation. Damage detection and removal within an appropriate time can increase the lifetime and safety of the structure and prevent it from total failure Navabian et al. (2016). Therefore, monitoring the integrity of structures on a continuous basis after severe events such as strong earthquakes is crucially significant from both life-safety and economic points of view. There are many methods developed for Structural Health Monitoring (SHM) in the literature. Cross et al. (2013) introduced a broad monitoring campaign of a suspension bridge called Tamar. They carried out structural analysis to assess the normal condition of the bridge due to the effects of temperature, traffic-induced vibrations and wind speed on dynamic responses of the structure. In another study, Abdelgawad and Yelamarthi (2017) developed a real-time SHM platform combined with IoT technology. The system includes a Wi-Fi module, a Raspberry Pi, an Analogue to Digital Converter (ADC), a Digital to Analog Converter (DAC), a buffer, and piezoelectric (PZT) sensors. Generally, vibration-based analysis techniques are among the most widely-used techniques by researchers to monitor the condition of civil engineering structures Huang (2018). To use such systems, dynamic testing, including the forced and ambient vibration tests, can be carried out using the sensor technology integrated within the structures. Traditional SHM systems use cables to transfer the measurements to a central data logger. Such systems usually incur high installation costs and long setup times especially for large civil infrastructures. Due to the high cost and complexity of traditional wired SHM systems, the improvement in Micro-Electro-Mechanical System (MEMS) provides researchers with great opportunities to develop sensing system with sensing capabilities, wireless communication and data processing options for reliable SHM

applications. This improvement could provide a successful implementation of large sensing networks throughout large civil structures by limiting the complexity and high cost associated with the traditional wired SHM systems Pakzad (2008). In the literature, there are several research conducted to develop wireless sensors for SHM applications. Hu and Wang (2013) developed an integrated structural health monitoring system for highway bridges based on a customized wireless sensor network. The designed platform could provide different types of sensors for SHM applications including accelerometers, strain gauges and temperature sensor. Zhu et al. (2018) designed a new high resolution accelerometer node for structural health monitoring applications. In another study, Fu et al (2018) presented a demand-based wireless smart sensor to record the critical information of an event such as strong earthquakes. Based on the lab and field experiments, it was observed that the demand-based wireless sensor is able to seamlessly record the vibration induced by events in an efficient manner. In this paper, the results of condition monitoring of one the most important civil engineering structures in New Zealand, Newmarket Viaduct, is presented. To do, one span of the bridge is instrumented using a new wireless accelerometer sensor node developed as a part of an integrated SHM system. The system has been developed to address the limitations associated with traditional wired SHM systems to measure both low-amplitude ambient vibration and high-amplitude earthquake-induced vibration from large-scale civil structures. For monitoring of the bridge performance, the dynamic characteristics measured using the new wireless sensor nodes are compared with the counterparts obtained during previous ambient vibration tests conducted on the bridge at various construction phases.

2 DEVELOPED WIRELESS SENSORY SYSTEM

The wireless sensor network specially developed as a part of an integrated SHM system is presented in this part of the paper. The system includes two major components including wireless sensor nodes and base station unit. Figure 1 shows the schematic design and final prototype of the new wireless sensor node designed to collect both ambient and earthquake-induced vibration.

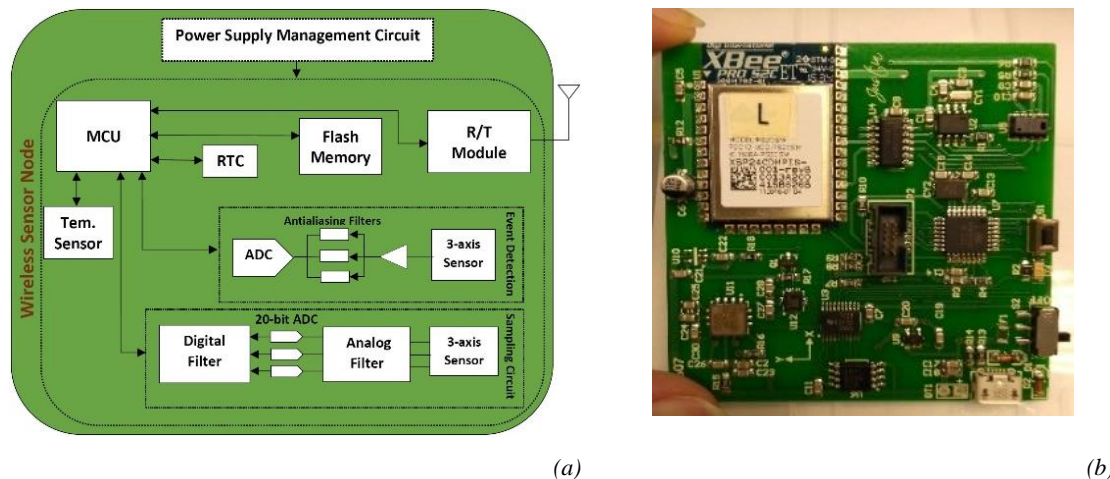

Figure 1. (a) Schematic diagram, and (b) manufactured version of the wireless sensor node.

The main components of the wireless sensor node are: (1) a pico-power microcontroller, (2) a XBee S2C RadioFrequency (RF) module (3) an external flash memory for data storage, (4) a Real-Time Clock (RTC), (5) a humidity and temperature sensor, (6) a 3-axis ultralow noise density accelerometer with an integrated 20-bit Analogue-to-Digital Converter (ADC), (7) an ultralow power 3-axis MEMS accelerometer with motion detection feature, and (8) a USB connector. Atmel picoPower microcontroller was selected due to its low power consumption in

active and sleep modes and its low cost. This chip has user-selectable clock frequency ranging from 4MHz to 20MHz which is adequate for SHM applications. This MCU could provide a great trade-off between accuracy, cost and power consumption which is the main goal of the board design. A standard low-power wireless communication format of IEEE802.15.4, called ZigBee, was used for wireless communication between sensor nodes and the gateway unit. This protocol is a low-cost and easy-to-employ module which could provide quick and seamless communication between nodes. In addition, a 64Mbit SPI external flash memory was selected to temporarily store the vibrations before wireless transmission. For environmental parameters, a fully calibrated humidity and temperature sensor with low power consumption and high accuracy was selected. In addition, a highly sensitive and low power 3-axis digital accelerometer was selected to measure very low-amplitude vibration measurements. This accelerometer supports $\pm 2.048g$, $\pm 4.096g$, and $\pm 8.192g$ ranges with minimal offset drift over temperature and long term stability enabling precision applications with minimal calibration. This low-power and low-cost chip has an ultralow noise density of $25 \mu g/\sqrt{Hz}$ in all axes and internal 20-bit ADC to digitize the filtered analogue signal. This accelerometer uses an analogue, low-pass, antialiasing filter and an additional digital filtering option including low-pass and high-pass filters to maintain excellent noise performance at various bandwidths. Thanks to high resolution and performance of the accelerometer, it was selected for the design of the high-performance series of wireless sensor nodes. For measuring earthquake-induced vibration, a digital output MEMS accelerometer was added to the board design to trigger the sensor board to record the earthquake-induced vibration. This accelerometer consumes less than $2\mu A$ at a 100Hz output data rate and $270nA$ when in motion triggered wake-up mode. The component specifications of the sensor including their power consumption in active and sleep modes are presented in Table 1.

The base station unit is the heart of the system and consists of a fanless design PC, a Mobile Wi-Fi modem for remote access to the system, and an XBee Pro Series 2C module, all enclosed by a weatherproof plastic enclosure. The Intel Core i7-7600U Processor was selected to manage the whole wireless SHM system due to its high power, fanless design, and high storage capacity required for SHM applications.

Table 1. Specification of the developed wireless sensor node.

Components	Manufacturer	Active Current (mA)	sleep Current (μA)
Low-power microcontroller	Atmel Inc.	0.2	0.1
Receiver-Transmitter module	Digi International Inc.	TX: 33 RX: 28	< 1
Real-Time Clock	Microchip Inc.	1.2×10^{-3}	< 0.2
Flash memory	STMicro. Inc.	10	20
Temperature & humidity sensor	Amphenol Inc.	0.75	0.6
Low-noise digital accelerometer	Analog Devices Inc.	0.013	0.01
Motion detection accelerometer	Analog Devices Inc.	0.2	21
Total power requirements:		45 mA	43 μA

3 DESCRIPTION OF THE NEWMARKET VIADUCT

The original Newmarket Viaduct was constructed in 1966 as one of the most significant bridges in New Zealand and the first post-tensioned balanced cantilever bridge along the country. After over 40 years in operation, it was decided to replace the superstructure due to the on-going structural deterioration and continuing pressures of the motorway network's capacity. The replacement of the bridge, constructed in 2009, is a horizontally and vertically curved, post-tensioned concrete box bridge, comprising two parallel twin bridges. The Northbound and Southbound Bridges are supported on independent pylons and joined together via a cast in-situ concrete 'stich'. The total length of the bridge is 690m including twelve different spans ranging in length from 38.67m to 62.65m and average length of approximately 60m Chen (2015). Figure 2 shows the view and plan of the Newmarket Viaduct located in Auckland city.



Figure 2. The view and plan of the Newmarket Viaduct in Auckland (<https://www.nzta.govt.nz/>).

A set of ambient vibration testing were carried out on the viaduct at different construction phases. The first test (Test 1) was done on November 2011 before casting the concrete 'Stich' only on southbound of the bridge. The following test, Test 2, was performed on November 2012 immediately after casting the concrete stich on both southbound and northbound of the bridge. Another set of ambient vibration testing was performed on the bridge to assess its performance after four years of operation. For all the mentioned tests, a number of standalone accelerometer was installed inside the concrete box of the bridge to measure the ambient vibration induced by traffic. The dynamic characteristics of the bridge measured during these three tests will be used in this study for structural condition assessment after eight years of operation.

4 BRIDGE INSTRUMENTATION

In this part, the layout of the sensor instrumentation on the Newmarket Viaduct is presented. The wireless accelerometer sensors was installed on span 9 of the bridge with the length of 59.13m (Figure 3). The instrumentation was carried out on December 1, 2018 under operational conditions, which did not interfere with the flow of the traffic over the viaduct. A total of 14 measurement points were selected inside the concrete box girder on both side of the span for installing the wireless sensors. Also, another 6 measurement points was considered on the post-tensioning cables to measure the vibration of the cables due to the traffic loading. Figure 4 shows the locations of the sensors and the base station unit inside the concrete box.



Figure 3. Bridge instrumentation using the wireless sensory system.

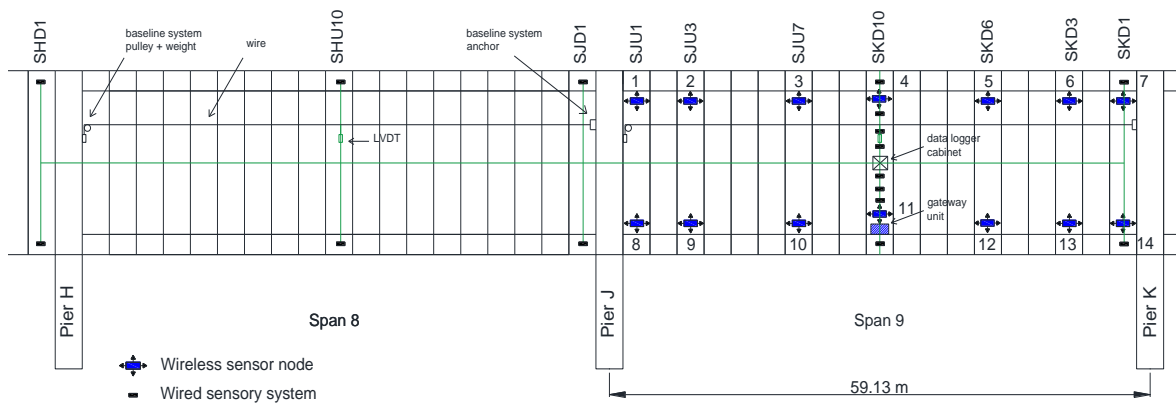

Figure 4. Locations of the wireless SHM system inside the concrete box of the Newmarket Viaduct.

The wireless sensors recorded ambient vibration in 3 axes with sampling time of 15 minutes and sampling frequency of 62.5Hz. It should be mentioned that only one week of ambient vibration dataset recorded from 1st Dec to 7th Dec 2018 are analysed in this paper. The base station was connected to the bridge electrical system to supply a continuous power. In addition, the sensor nodes were powered by a 12000mAh USB battery pack to increase the network lifetime.

5 RESULTS OF THE AMBIENT VIBRATION TEST

The results of modal analysis on vibration data recorded from the bridge and the post-tensioning cables are presented in the following parts. It is noteworthy that the vibration recorded from longitudinal direction of the bridge is ignored from the analysis, as they are not significant for dynamic assessment of the bridge. The analysis was carried out using a system identification toolbox developed in MATLAB Beskhyroun (2011). The Power Spectral Density (PSD) values of acceleration data recorded from the bridge deck and the post-tensioning cables was obtained after preliminary data manipulation. Figure 5 presents the time series acceleration recorded by Ch.11, located at the middle of the span, and Ch.18, attached on the post-tensioning cable, in transverse and vertical directions. The datasets were recorded at 1:00pm during one week of monitoring period.

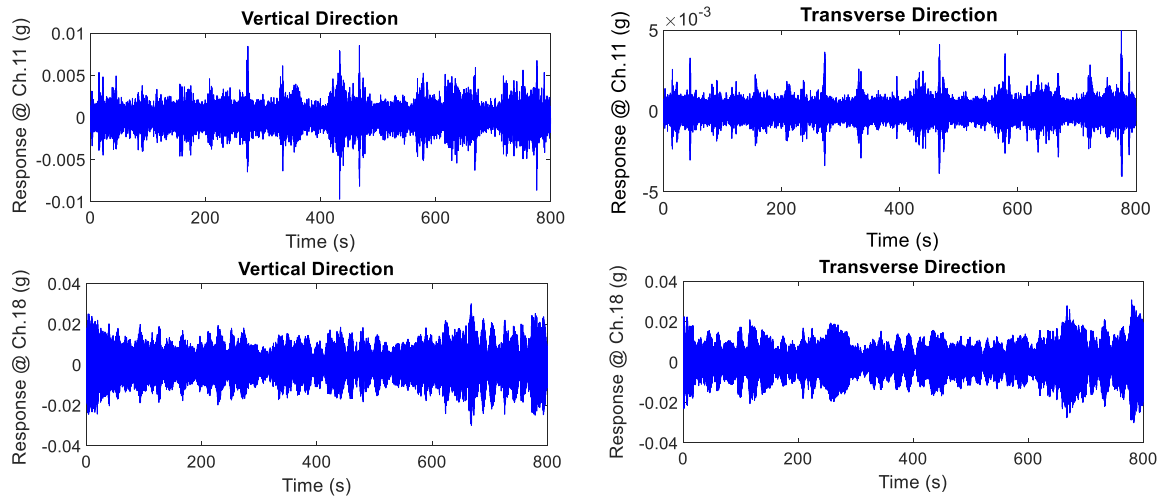

Figure 5. Time series acceleration recorded by Ch.11 (from bridge deck) and Ch.18 (from post-tensioning cables) in vertical and transverse directions.

The corresponding PSD values of acceleration data recorded from the bridge deck and the post-tensioning cable are presented in Figure 6. As is obvious from the results, the PSD magnitudes obtained from the data on weekend (December 1 & 2) are less than the values obtained during weekdays because of less traffic loads on the bridge during the first two days of the monitoring period. The results show a good consistency between the PSD values obtained from different datasets recorded at different days of a week.

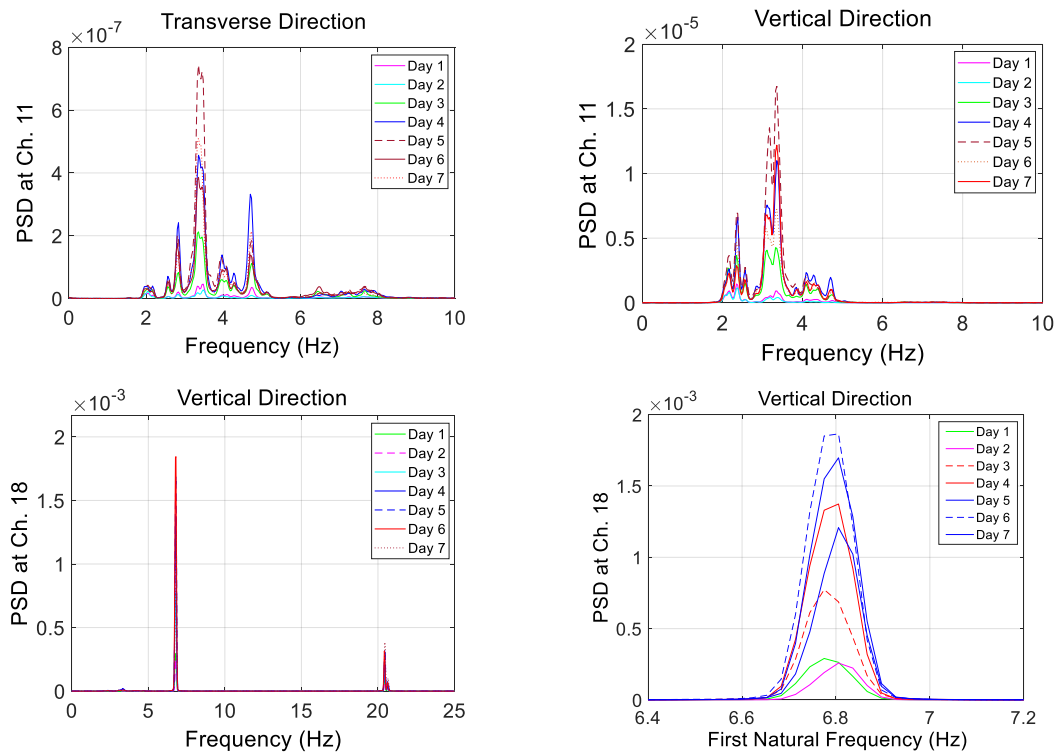

Figure 6. Power spectral densities of acceleration recorded by Ch.11 (from bridge deck) and Ch.18 (from post-tensioning cable).

To identify the dynamic characteristics of the bridge after several years of operation, the vibration datasets were analysed using Enhanced Frequency Domain Decomposition (EFDD) method. Figure 7 shows the variation of frequencies for the first two transverse and first four vertical modes of the structure using the vibrations recorded by Ch.4, located at the middle of span 9. A good consistency in natural frequencies was observed during one week of the monitoring period. The small variations between the frequencies could be due to the stationarity of signal and accuracy of computational algorithm.

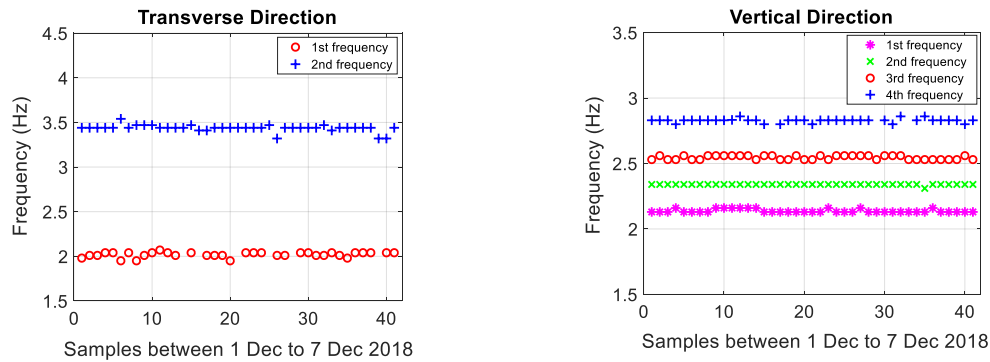

Figure 7. Variation of bridge modal frequencies measured by Ch.4 during one week of monitoring period.

The results obtained during the conducted ambient vibration test (T4) using the developed wireless sensors are compared to the identified counterparts measured during Test 1, Test 2 and Test 3 carried out at different construction phases. Table 2 shows the first two transverse and first four vertical natural frequencies measured using different datasets. As is obvious, there is a very good match between the transverse and vertical natural frequencies obtained from different ambient vibration tests. This consistency in dynamic characteristics of the bridge shows there is no significant changes in bridge dynamic performance after several years of operation. A small difference between the results of Test 1 and Test 2-Test 4 is due to the fact that they were conducted on the viaduct at different construction phases. Generally, the results obtained in this paper indicate a reliable performance of the wireless sensor nodes to record low-amplitude ambient vibration for SHM applications.

Table 2. Natural frequencies measured during four stages of ambient vibration tests on the bridge.

Test	Transverse modes (Hz)		Vertical modes (Hz)				
	T1*	T2	V1	V2	V3	V4	V5
1	1.05±0.00	1.41±0.03	2.12±0.02	2.25±0.01	2.43±0.02	2.66±0.04	2.88±0.02
2	1.25±0.01	1.56±0.00	2.03±0.01	2.15±0.00	2.34±0.00	2.54±0.03	2.82±0.02
3	1.25±0.01	1.56±0.00	2.03±0.00	2.15±0.00	2.34±0.00	2.54±0.00	2.82±0.01
4	1.25±0.03	1.55±0.03	2.04±0.03	2.13±0.03	2.34±0.00	2.56±0.03	2.83±0.03

*T1=transverse mode 1 (V=vertical)

6 CONCLUSION

In this study, one of the most important civil engineering structures in New Zealand, the Newmarket Viaduct in Auckland, is instrumented using a new developed wireless sensors to assess the performance of the bridge after several years of operation. The new wireless sensor network is a part of an integrated structural health monitoring system for long-term monitoring of large-scale civil structures. During the ambient vibration testing, the performance of the wireless sensors in terms of sensor resolution, wireless communication, and power consumption are also investigated for a robust SHM system. In addition, for long-term monitoring of the bridge performance, the identified natural frequencies are compared to the identified counterparts measured during different ambient vibration tests carried out on the bridge at different construction phases. The natural frequencies extracted from vibration data collected at different construction stages indicate no obvious changes in the performance of the superstructure under operational loading after several years of operation. In addition, the consistency in the dynamic characteristics of the bridge measured during all ambient vibration tests prove the performance of the sensors and the reliability of wireless communication for SHM application. Further development of the wireless sensor nodes for long-term monitoring is under progress.

ACKNOWLEDGMENT

This research is financially supported by New Zealand Earthquake Commission (EQC). The great support of New Zealand Transportation Agency (NZTA) is acknowledged for providing permission to instrument the Newmarket Viaduct. The help of Kelly Cheung for the bridge instrumentation is acknowledged. Also, many thanks to Justin Matulich for all his great assistance in manufacturing the sensor boards.

REFERENCES

- Abdelgawad, A., Yelamarthi, K. 2017. Internet of Things (IoT) Platform for Structure Health Monitoring. *Wireless Communications and Mobile Computing*, 2017.
- Beskyroun, S. 2011. Graphical interface toolbox for modal analysis, in *Proceeding the 9th Pacific Conference on Earthquake Engineering: Building an Earthquake-Resilient Society*, Auckland, New Zealand.
- Chen, X. 2015. Assessment of the dynamics and performance of an in-service twelve-span twin bridge using in-situ testing and finite element modelling (Doctoral dissertation, ResearchSpace@ Auckland).
- Cross, E., Koo, K., Brownjohn, J., & Worden, K. 2013. Long-term monitoring and data analysis of the Tamar Bridge. *Mechanical Systems and Signal Processing*, 35(1), 16-34.
- Hu, X., Wang, B., & Ji, H. 2013. A wireless sensor network-based structural health monitoring system for highway bridges. *Computer-Aided Civil and Infrastructure Engineering*, 28(3), 193-209.
- Huang, M.-S., M. Gül, and H.-P. Zhu. 2018. Vibration-Based Structural Damage Identification under Varying Temperature Effects, *Journal of Aerospace Engineering*, Vol 31(3), 04018014.
- Pakzad, S.N., et al. 2008. Design and implementation of scalable wireless sensor network for structural monitoring, *Journal of infrastructure systems*, Vol 14(1) 89-101.
- Navabian, N., Bozorgnasab, M., Taghipour, R., & Yazdanpanah, O. 2016. Damage identification in plate-like structure using mode shape derivatives. *Archive of Applied Mechanics*, 86(5), 819-830.
- Fu, Y., Hoang, T., Mechitov, K., Kim, J., Zhang, D., & Spencer, B. 2018. Sudden Event Monitoring of Civil Infrastructure Using Demand-Based Wireless Smart Sensors. *Sensors*, 18(12), 4480.
- Zhu, L., Fu, Y., Chow, R., Spencer, B., Park, J., & Mechitov, K. 2018. Development of a high-sensitivity wireless accelerometer for structural health monitoring. *Sensors*, 18(1), 262.